

Observation of the Direct $S_2 \rightarrow S_0$ Two-Photon Fluorescence between 370 and 480 nm and the Hyperpolarizability of Crystal Violet (CV) from Spectrally Resolved Hyper-Rayleigh Scattering Measurement[†]

Yi Rao, Xun-min Guo, Yi-Song Tao, and Hong-fei Wang*

State Key Laboratory of Molecular Reaction Dynamics, Center for Molecular Sciences, Institute of Chemistry, the Chinese Academy of Sciences, Beijing, People's Republic of China, 100080

Received: February 14, 2004; In Final Form: March 15, 2004

We present the observation of the direct $S_2 \rightarrow S_0$ two-photon fluorescence (TPF) of crystal violet (CV) in methanol solution. The $S_2 \rightarrow S_0$ emission spectra of CV with excitation wavelengths from 730 to 900 nm are obtained for the first time. These spectra present three clear features: the broad $S_2 \rightarrow S_0$ TPF (370–480 nm) peaked at 408 nm, the hyper-Rayleigh scattering (HRS) at half of the excitation wavelength, and the hyper-Raman scattering with a Stokes shift about 1415 cm^{-1} from the HRS wavelength, which can be attributed to the phenyl groups in the CV molecule. The two-photon excitation spectra measured from this $S_2 \rightarrow S_0$ emission is peaked at $374 \pm 2 \text{ nm}$. This TPF emission has the same depolarization ratio as the HRS signal, indicating a lifetime much shorter than the rotational relaxation lifetime. Subtraction of the TPF contribution leads to a hyperpolarizability value of CV at 800 nm, which is much smaller than that previously reported. Moreover, with the ability to directly measure HRS of the pure solvent, the hyperpolarizability value of CV also has much higher precision.

1. Introduction

Crystal violet (tris(*p*-(dimethylamino)phenyl)methyl ion or CV) is one of the widely studied organic molecules for fundamental understanding of molecular structural and dynamic properties, as well as technological applications.¹ CV and malachite green (MG) have also been considered the prototype molecules among the extensively and long studied triphenylmethane (TPM) dyes.^{1–4} In the past decade or so, CV has also been intensively studied as the prototype octopolar molecules for nonlinear optics.^{5–7}

The relaxation dynamics of the higher excited states of organic molecules is of great importance for understanding the photophysical and photochemical processes of molecules.^{4,8,9} Recently, the ultrafast relaxation dynamics of MG in polar media (water, ethanol, etc.) determined from its S_2 fluorescence has been reported.^{4,9} Because MG has C_2 symmetry while CV is D_3 , their electronic absorption spectra are significantly different. For MG, its first three absorption bands are peaked around 620 nm, 425 nm, and 310 nm, respectively, while for CV, there are only two absorption bands in this region, namely, around 590 nm and 305 nm.^{1,10} Therefore, it is surprising that a two-photon absorption band peaked at 376 nm was observed recently from its two-photon excitation spectra, measured from the integrated intensity over a weak broad-band $S_1 \rightarrow S_0$ fluorescence around 670 nm.¹¹ However, unlike MG, the direct fluorescence emission from this two-photon absorption state is considered far too weak to be observable.

To our surprise, in the wavelength-resolved hyper-Rayleigh scattering (HRS) measurement of CV both in methanol and water around 400 nm, we observed a fairly strong broad-band emission between 370 and 480 nm peaked around 408 nm. The

two-photon excitation spectra measured from this emission is peaked at $374 \pm 2 \text{ nm}$, which overlaps well with the two-photon excitation spectra from the $S_1 \rightarrow S_0$ fluorescence data in the literature.¹¹ This fact indicates that this emission comes most likely from the direct fluorescence emission from the two-photon absorption band.

It was also observed that this emission overwhelms the HRS signal of CV at 400 nm. This emission should have important consequences on the value of hyperpolarizability of CV from HRS measurement using the typical 800-nm femtosecond laser light. Even though HRS in solution was first observed in 1965,¹² and the theory of HRS in solution had been developed by Bersohn¹³ and others¹⁴ soon after, it is in the 1990s that HRS has been playing an important role in determining second-order nonlinearity coefficients of molecules in solution.^{6,7,15} HRS is especially useful for measurement of the hyperpolarizability of the octopolar or multipolar molecules, which have interesting photophysical properties themselves and have potential advantages in application for nonlinear optical devices.⁵ CV is one of the few prototype octopolar molecules, whose nonlinearity has been widely studied both experimentally^{11,16,17} and theoretically.^{18,19} Femtosecond pulsed lasers have been introduced for HRS measurement in the middle 1990s to achieve higher detection sensitivity for the weak HRS processes in solution.²⁰ Furthermore, HRS of CV measured with 800-nm femtosecond light has been the benchmark experiment.⁶

However, accurate determination of the hyperpolarizability of organic molecules in solution is not always achievable. Great efforts have been dedicated to improve the precision of HRS measurements.²¹ The influence of the two-photon fluorescence and other emission on the HRS measurement has been intensively discussed in the literature.^{16,17,22,23} Proposals to circumvent the problem include using longer fundamental wavelength to avoid multiphoton excitation,^{17,22} time-resolved pump-probe

[†] Part of the special issue "Richard Bersohn Memorial Issue".

* Author to whom correspondence should be addressed. Fax: 86-10-62563167. E-mail: hongfei@mrmlab.icas.ac.cn.

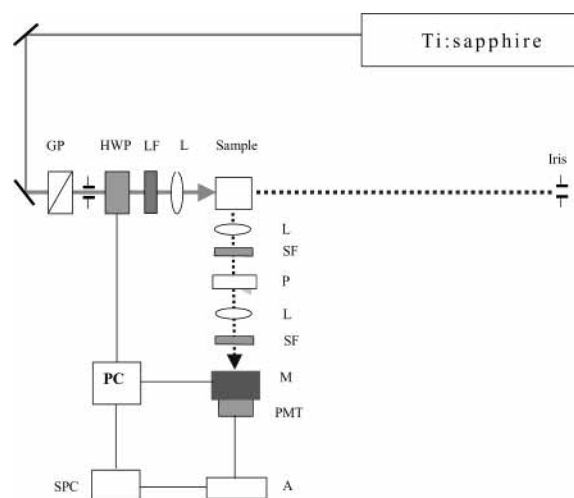

Figure 1. Schematic setup of the hyper-Rayleigh scattering measurement at the perpendicular direction. GP: Glan prism; HWP: half-wave plate; LF: long-wave pass filter; L: lens; SF: short-wave filter; M: monochromator; A: preamplifier; SPC: photon counter.

technique,²³ as well as the ingenious high-frequency demodulation technique.¹⁶ The last technique is useful for eliminating contributions from unwanted emission with a lifetime longer than 1 ns, limited mainly by the experimentally achievable upper limit of the modulation frequency.¹⁶ If the lifetime of the emission we observed is much faster than 1 ns, this demodulation technique should not be able to eliminate this TPF signal from the HRS of CV at 400 nm. Therefore, in this aspect it is also imperative to investigate the nature of this newly observed 370–480-nm emission band of CV.

In this study, we will first present the wavelength-resolved measurement and characterization of the direct $S_2 \rightarrow S_0$ two-photon fluorescence (TPF) of CV in methanol solution. Then, we will discuss the measurement of hyperpolarizability of CV at 400 nm with the correction of this $S_2 \rightarrow S_0$ fluorescence. These results will certainly shed new light on our understanding of the electronic structure, photophysics, and dynamic properties of this intensively studied molecule and beyond.

2. Experimental Section

Femtosecond Hyper-Rayleigh Scattering Detection System. We used a typical experimental setup measuring hyper-Rayleigh scattering at 90° . An important aspect in our experimental setup is that it enables us for sensitive detection of the weak fluorescence and HRS signals.¹¹ To achieve higher sensitivity for weak signals, we used a high repetition rate broadband femtosecond laser source with single-photon detection electronics, other than using the high repetition rate femtosecond laser with a lock-in detection technique,²⁰ or an amplified kilo Hz femtosecond system with a cooled CCD detection system.¹¹ In this approach, the sensitivity could be several orders higher sometimes. We have used this laser and detection systems in earlier SHG reflection studies. It not only enabled us to easily detect the very weak SHG signal from the neat air/water interface,²⁴ but also enabled us to perform quantitative analysis of the small changes of the SHG signal from different polarizations.²⁵

The femtosecond laser source we used is a broad-band (700–1000-nm) tunable mode-locked Ti:Sapphire laser pumped by a 10 W diode laser (Millennium Xs + Tsunami 3955, Spectra-Physics, Inc). This laser system is tunable in the whole 700–1000-nm range (with proper purge of water vapor in the laser cavity) with only one set of mirrors. It is especially convenient

for the broad-band excitation experiment. Its high-repetition rate (82 MHz) and short pulse width (~ 80 fs) is good for detection of very weak signals with a single-photon-counting technique. As shown in Figure 1, the laser beam passes a Glan prism, a half-wave plate, and a long wavelength pass filter, used to eliminate the possible second-harmonic photons in the laser beam, before the laser beam with only the fundamental frequency is focused into the solution sample cell with a 50-mm focal lens. Typically, a 10×10 mm fluorescence quartz cell was used as a sample cell. The scattered and emitted light was collected with a condenser lens ($f = 50$ mm) at the right angle direction. After a short wavelength pass filter to filter out the scattered fundamental light, the signal is collimated and focused into a monochromator before entering the photomultiplier tube (PMT).

A monochromator (1200 lines/mm grating, blazed at 350 nm) with a 2 nm resolution was used to resolve the spectra. A Hamamatsu PMT (R585, spectral range 160–650 nm) and a photon counter (SR400, SRS) with preamplifier (SR240, SRS) were used for single-photon-counting detection. All collection optical parts, the monochromator, and the PMT are placed in a long plate fixed on a rotating goniometer. The sample cell is placed in the center of this goniometer, and the cell holder is fixed on the optical table. To make sure the focus point is in the center of the sample cell, we used the two-photon fluorescence of Rhodamine B methanol solution to calibrate the position the focusing point. Then, a high concentration CV methanol solution is used to optimize the signal collection optics. Data acquisition and the controls of the moving optical parts are all interfaced with a PC computer.

Material Preparation and Test. To independently check if impurities other than CV contribute to the observed emission, crystal violet chloride was obtained from different suppliers, including Aldrich, TCL, and the Beijing Chemical Reagents Company (BCRC). The unpurified and purified (through recrystallization from methanol solution up to three times) CV solution all give the same emission between 370 and 480 nm. Analytical grade methanol as the solvent was obtained from BCRC. The pure methanol has no emission features in the region between 380 and 480 nm. This should eliminate the possibility of impurity contribution.

All solutions were prepared and filtered with a filtering injector (0.2- μ m Syringe Filter, Millipore, Inc.) before the scattering measurement to avoid optical breakdown in the cuvette surface or generation of hyper-Mie scattering because of dust or unsolved solute particles in the focusing path of the light beam. The concentrations of all samples after filtering are calibrated with standard UV/vis spectrum using a standard concentration.

3. Results and Discussion

3.1 The $S_2 \rightarrow S_0$ Direct Emission Band of CV between 370 and 480 nm. The unpolarized spectrally resolved signals from the CV methanol solution (5 μ M) with different excitation wavelengths from 740 to 900 nm were recorded from 350 to 600 nm (Figure 2 with eight spectra excited under 740, 760, 780, 800, 820, 840, 860, 900 nm, respectively). The spectra under 740 nm, 760 nm, and 780-nm excitation wavelength all show a single broad peak (from 370 to 480 nm) centered at 408 nm with decreasing peak intensity. This emission band becomes several orders of magnitude weaker as the excitation wavelength increases from 740 to 900 nm. Figure 3 gives the

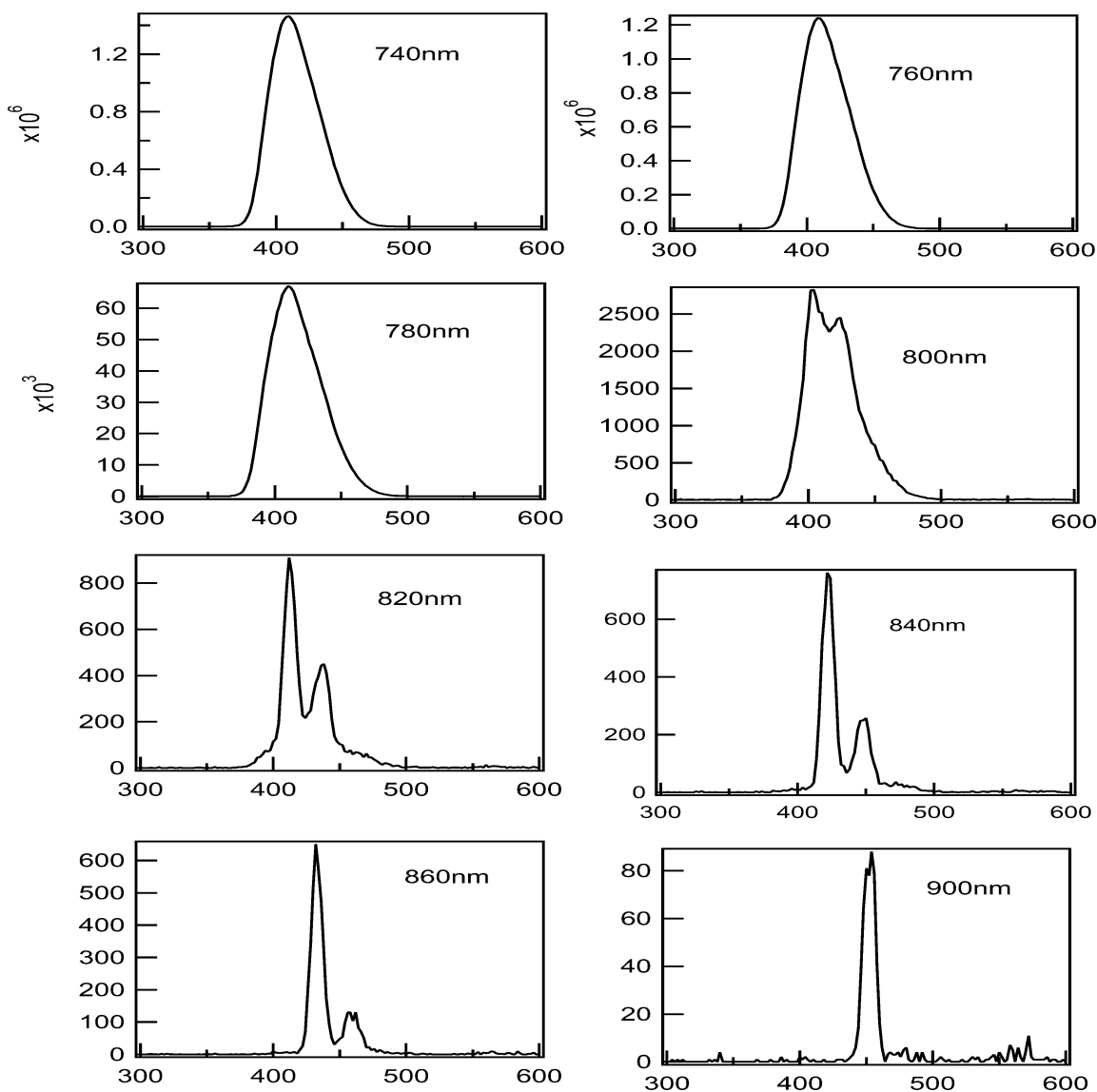

Figure 2. The unpolarized emission spectra of crystal violet in methanol in 300–600 nm at different excitation fundamental wavelengths. The power of the laser was kept at 400 mW for all the wavelengths, except that it is 150 mW for 900-nm excitation. This reduction of laser power is due to the water vapor in the unpurged laser cavity. The resolution of the spectra is 2 nm, and each step between consecutive data points is 0.5 nm. Spectra with very similar features were also observed for CV in aqueous solution.

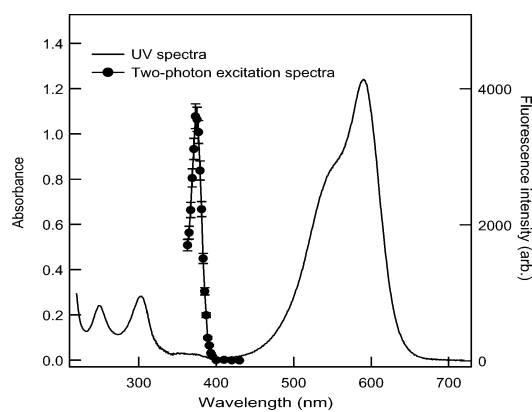

Figure 3. Left: The UV/vis absorption spectra of CV in methanol (10 μM solution). Right: the two-photon excitation spectra measured with the emission at the 408 nm. Sampling time is reduced many times to avoid saturation of the photon counter at the TPA peak wavelength.

excitation spectra recorded at the peak of this band at 408 ± 2 nm and the UV/vis spectra of the CV methanol solution (10 μM). It is clear that this excitation spectra peaks at 748 ± 2

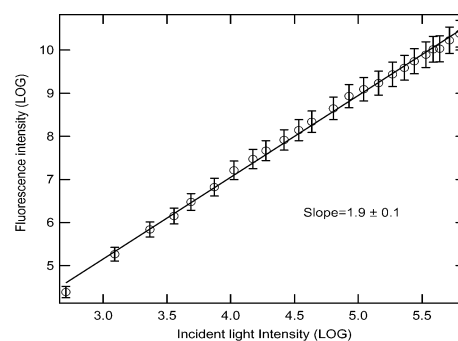

Figure 4. Laser power dependence of the 408-nm emission excited with 750-nm fundamental light. The slope of the log–log plot is 1.9 ± 0.1 .

nm (two-photon wavelength at 374 ± 2 nm). The power dependence of the emission spectra at 408 ± 2 nm under 748-nm (the two-photon absorption peak position) excitation indicates that this emission is a two-photon process. (Figure 4, power order = 1.9 ± 0.1) From all this evidence, this band must originate from two-photon fluorescence emission. Since the S_1

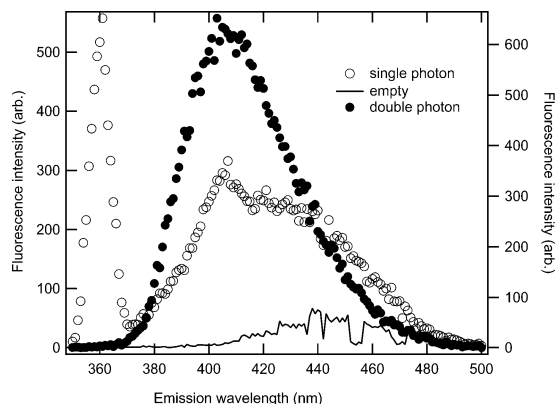

Figure 5. The emission spectrum of crystal violet, under 365-nm (one-photon, left) and 730-nm (two-photon, right) excitation wavelength.

$\rightarrow S_0$ fluorescence emission is in the range of 600–800 nm peaked at 640 nm,¹⁷ this emission has to come from direct fluorescence emission from higher excited states.

An emission in the wavelength range 380–480 nm of a methanol solution of CV excited with a nanosecond laser at 1064 nm was previously reported by Wong et al.¹⁷ However, since there was no available excited states known for CV around 355 nm, which is the third-harmonic wavelength of 1064 nm, this emission was attributed to a three-photon absorption-induced fluorescence from an impurity.¹⁷ Recently, a two-photon absorption band (peaked at 376 nm) was observed from the two-photon excitation spectra of CV in glycerol, integrated over a weak broad-band $S_1 \rightarrow S_0$ fluorescence around 670 nm.¹¹ Because the low detection sensitivity failed to obtain the wavelength-resolved emission spectra in the range of 380–480 nm, no direct emission from higher excited states were observed.¹¹ However, the reported excitation spectra obtained from $S_1 \rightarrow S_0$ fluorescence¹¹ overlap well with the excitation spectra (Figure 3) obtained from the 408-nm emission. This fact excludes the possibility that this 370–480 nm emission comes from impurity molecules. Therefore, we can conclude that this recently reported two-photon absorption (TPA) band is the origin of the direct emission observed in our experiment.

We further found out that this two-photon absorption band is also one-photon allowed. Using a BBO doubling crystal, we generated femtosecond pulses around 365 nm. In Figure 5, the single-photon excitation at 365 nm gives a broad-band emission in the 370–480 nm region peaked at 408 nm. The shoulder on the right side of this band could be attributed to the Stokes Raman bands from the CV molecules or the solvent. The single peak at about 365 nm is the scattered light from the strong 365-nm beam. In Figure 5, the emission spectra of two-photon excitation at 730 nm is also presented. It is clear that both one-photon and two-photon excitation have almost the identical emission spectra. Therefore, this two-photon allowed excitation band is also one-photon accessible. Thus, this absorption band can be labeled as the S_2 electronic state, and the 370–480-nm emission band is the direct $S_2 \rightarrow S_0$ fluorescence emission.

To deduce more information on the symmetry of this S_2 state, the ratio of the TPF intensities excited with circularly polarized and linear polarized lights at 750 nm is determined. This value is 0.67, which indicates that this S_2 state has to have strong A state characterization.²⁶ However, since this state is also one-photon allowed as shown in Figure 5, it cannot be a pure A state, and the molecule must deviate from a simple C_3 or D_3 structure.¹¹ It is interesting to see that there is a small plateau or weak peak region between 340 and 390 nm in the UV/vis spectra (Figure 3) This could account for the feature of the weak

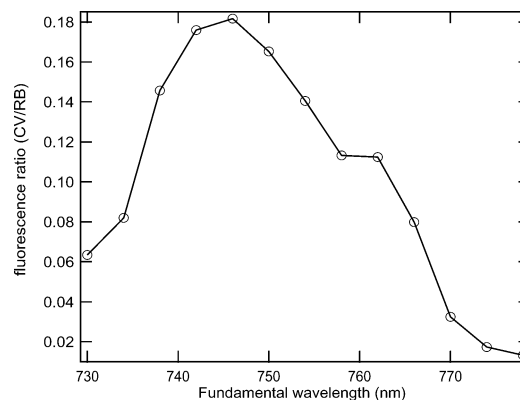

Figure 6. Fluorescence intensity ratio of CV and Rhodamine B in methanol solution under different excitation wavelength. Both concentrations used are 10 μ M.

one-photon allowed S_2 electronic state. However, it is somewhat strange that the measured two-photon excitation spectrum is very sharp compared to the linear UV/vis absorption spectrum in this wavelength region. These intriguing facts warrant further investigation of the electronic state structure as well as excited-state dynamics of the CV molecule in this spectral region.

The depolarization ratio for the TPF intensity at 408 nm excited with 750-nm light is measured. This ratio with 1.7 ± 0.2 indicates that the TPF is anisotropic. Therefore, the TPF must come from the CV molecule before it has time to rotationally relax. The TPF lifetime must be much shorter than the rotational relaxation time, which is usually in the picosecond time scale or less. Since the direct two-photon emission or HRS process from a D_3 state should have a depolarization ratio as 1.5,^{27,7} this S_2 excited state must have a distorted geometry, but not far from the D_3 structure. On the basis of above evidences, this S_2 excited state must assume a slightly drooping propeller structure with nonuniformly twisted arms, since it can neither be a pure C_3 nor D_3 symmetry.

We have also measured the ratio between the two-photon $S_2 \rightarrow S_0$ fluorescence intensity of the CV molecule in methanol from 730 to 780 nm, calibrated against the two-photon $S_1 \rightarrow S_0$ fluorescence intensity of Rhodamine B in methanol (Figure 6).^{28,29} Because the fluorescence quantum yield and cross section of Rhodamine B at different wavelengths are known,^{28,29} this gives a measure of the TPA cross section (δ) and the $S_2 \rightarrow S_0$ fluorescence quantum yield (η). At 750-nm excitation, we obtained $\eta\delta = 47.17 \times 10^{-50} \text{ cm}^4 \cdot \text{s}$ for CV. Since absorption of a photon is such a fast process that it does not depend on the coupling between the solute and solvent molecules, it is reasonable to assume that the TPA cross section changes only slightly for the same molecule in different solvents. Assuming there is no radiationless relaxation from S_2 to states other than to the S_1 state, the TPA cross section measured from the $S_1 \rightarrow S_0$ fluorescence emission gives the lower limit of the true TPA cross section. Therefore, here we use the TPA cross section value $\delta = 1980 \times 10^{-50} \text{ cm}^4$ at 750 nm, which has been obtained from the $S_1 \rightarrow S_0$ fluorescence measurement for CV in glycerol at 752 nm,¹¹ to calculate the $S_2 \rightarrow S_0$ quantum yield. This gives 0.024 as the upper limit of the quantum yield for the direct $S_2 \rightarrow S_0$ fluorescence emission of CV in methanol.

We also observed $S_2 \rightarrow S_0$ fluorescence emission of CV in water. The spectral features were the same as those in methanol, and the intensities of the peaks at the same CV concentration were very close to what were observed in methanol solution. To our knowledge, such a direct $S_2 \rightarrow S_0$ fluorescence emission for CV or other octopolar molecules has not been previously reported.

It has been reported that the S_2 relaxation rate of MG in solution has a very weak dependence on the solvent viscosity (η), while the S_1 relaxation rate followed approximately an $\eta^{2/3}$ dependence.⁹ This means the $S_2 \rightarrow S_0$ fluorescence lifetime must be much shorter than the rotational diffusion time. Such dynamics studies for CV are yet to be carried out. However, we expect that the $S_2 \rightarrow S_0$ fluorescence lifetime would follow the same trend.

3.2 Hyperpolarizability of CV at 800 nm and 872 nm. It is a simple fact that the HRS scattering is centered at the doubled frequency, that is, half the wavelength, of the fundamental excitation wavelength. In Figure 2, two new sharp peaks started emerging from the 800-nm excitation spectra that became two clear peaks at longer wavelengths, while the 370–480-nm $S_2 \rightarrow S_0$ emission decreases more than 5 orders of magnitude from 740-nm excitation to 900-nm excitation. Both of the sharp peaks appear to have the same bandwidth as the femtosecond laser bandwidth. The left sharp peak is always at half of the excitation wavelength and also has a measured depolarization ratio that equals 1.5 ± 0.1 , which is the depolarization value for the excited states with octopolar symmetry.^{7,27} So, it can be attributed to the HRS of CV. The other peak always has a $1415 \pm 25 \text{ cm}^{-1}$ shift from the HRS peak in the same direction on each spectra. This peak can be attributed to a Stokes shift from the hyper-Raman scattering process, and this shift of $1415 \pm 25 \text{ cm}^{-1}$ is in coincidence with the vibrational stretch frequency of the phenyl ring in the crystal violet molecule.³⁰ It is clear to see in Figure 2 that when excited with wavelengths shorter than 800 nm, the HRS and hyper-Raman scattering are too weak to be seen, compared to the strong broad-band direct $S_2 \rightarrow S_0$ emission.

It is clear to see in Figure 2 that the HRS peak at 400 nm cannot be separated from the broad TPF emission band peaked at 408 nm when excited at 800 nm. In fact, the TPF signal is several times larger than that of the HRS. Fitting this spectra requires all three bands to be incorporated, even though the $1415 \pm 25 \text{ cm}^{-1}$ Stokes hyper-Raman peak is not easily apparent. At longer excitation wavelengths, the contribution of the TPF band becomes much smaller compared to the HRS and hyper-Raman signals. Thus, a single HRS peak clearly stands out when the excitation wavelength is above 840 nm. As we can also see, the hyper-Raman peak disappears when excited with 900-nm light. This can be accounted for by the decrease of the excitation laser power at 900 nm.

To obtain the value of the hyperpolarizability at 800-nm excitation, we have to use spectra fitting to subtract the contribution of the TPF. In doing so, we measured a series of spectra with different CV concentrations in methanol, ranging from $5 \mu\text{M}$ up to $50 \mu\text{M}$.

The total HRS signal is³¹

$$I(2\omega) = G^*(N_{\text{solvent}}^* \beta_{\text{solvent}}^2 + N_{\text{solute}} * \langle \beta_{\text{solute}}^2 \rangle) * I_0^2 \quad (1)$$

where G is the experimental constant with the same solvent; I_0 , the incident intensity; N , the number density; and $\langle \beta_i \rangle$, the orientational averaged hyperpolarizability. In the literature, since the pure solvent HRS signal is usually very small, extrapolation to the zero solute concentration is necessary to obtain the pure solvent contribution to the HRS signal, that is, the $G^* N_{\text{solvent}}^* \beta_{\text{solvent}}^2$ term.^{16,20,32} This method is called the internal reference method (IRM). If the solvent contribution is small, the extrapolated value would be close to zero.³³ Therefore, using IRM could induce a large inaccuracy in the hyperpolarizability value of the solute molecule. However, in our experiment, this extrapolation is actually unnecessary. Because of the high sensitivity of

our experimental system, the very weak HRS signal from the pure methanol, which is used as the internal reference standard, is about 50 counts/second at 800-nm excitation, well above the noise level below 5 counts/second. Because the CV methanol solution at low concentrations has very low absorption coefficient at 400 nm (well below $1000 \text{ cm}^2/\text{mole}$), deviation of the observed signal from the Lambert–Beer law is negligible with the concentrations used in our experiment. This would certainly make the correction for the reabsorption of the HRS signal unnecessary and further increase the accuracy and precision of the $N^* \langle \beta_{\text{solute}}^2 \rangle$ value. Therefore, the disadvantage of the IRM is essentially avoided. Furthermore, measurement of the HRS of the pure methanol and only one CV concentration is enough to obtain the effective hyperpolarizability value of CV in methanol, which makes the measurement procedure much simpler. Following the calculations in the literature, using the same $\beta_{333} = \beta_{\text{HRS}}$ of methanol as $0.26 \times 10^{-30} \text{ esu}$ ^{20,32} and the same tensor average relationship for CV with D_3 symmetry²⁷

$$\langle \beta_{\text{HRS}}^2 \rangle = \langle \beta_{zzz}^2 \rangle + \langle \beta_{yzz}^2 \rangle = \frac{8}{21} \beta_{333}^2 \quad (2)$$

we obtain $\beta_{333} = 162 \pm 22 \times 10^{-30} \text{ esu}$ for CV in methanol under 800-nm excitation after subtracting the TPF contribution to the 400-nm HRS peak. This value is significantly smaller than the previously reported value $\beta_{333} = 329 \pm 60 \times 10^{-30} \text{ esu}$,¹⁶ or $450 \pm 100 \times 10^{-30} \text{ esu}$ with 800-nm excitation.²⁰ It is clear that our result has a much better precision. Also, without excluding the contribution of the TPF from our experimental data, the hyperpolarizability value would appear to be about 4 times higher.

At 872 nm, the hyperpolarizability value of CV in methanol was reported in the literature as $\beta_{333} = 433 \pm 130 \times 10^{-30} \text{ esu}$.³² Clearly, no spectra subtraction is needed for HRS measurement at 872-nm excitation. Experiments gave us a value at 872 nm of $\beta_{333} = 148 \pm 22 \times 10^{-30} \text{ esu}$, which is slightly smaller than that of 800 nm in our experiment, and is more than 2 times smaller than that of the previously reported values.

It is understandable that the β values for CV at 800 nm and 872 nm are close, since these two wavelengths are both far removed from the peak of the two-photon absorption band (Figure 3). The previous reported β values at these two wavelengths also support this conclusion.^{16,20,32} However, our β values are systematically smaller than the previously reported ones for CV methanol solution. The only reason we can attribute this to is that we did the measurement at lower CV concentration, which avoids aggregates forming and correction for reabsorption, and also we used a very sensitive detection system which enables direct measurement of the HRS from the pure solvent. Of course, the very weak HRS signal of many pure solvents,³⁴ even gases,³⁵ were effectively measured long ago, with either intense nanosecond or picosecond laser pulses. Nevertheless, such intense lasers usually would cause breakdown or other higher order processes and would not allow measurements on organic molecular solutions.

4. Conclusion

The direct $S_2 \rightarrow S_0$ TPF emission of crystal violet in methanol is observed and characterized. This TPF band is very broad, emitting from 370 to 480 nm and peaked at 408 nm. Also observed is a hyper-Raman scattering peak with a Stokes shift about $1415 \pm 25 \text{ cm}^{-1}$, which can be attributed to the stretch mode of phenyl groups of crystal violet. This TPF band has a mixed A symmetry, and its lifetime appears to be very short. Since this is the first observation of the direct $S_2 \rightarrow S_0$ TPF

emission of an octopolar molecule, the same phenomena can be expected for other octopolar molecules, making it possible to directly measure the relaxation dynamics and photophysics of the S_2 states of similar molecular systems.

Because the TPF band and the HRS peak overlap in the 400-nm region, it is imperative to discriminate it from HRS measurement in this wavelength region. We believe that with very sensitive and spectrally resolved measurement techniques in future studies, many unresolved mysteries in HRS and other nonlinear optical measurements can be cleared up. Finally, the simplicity and advantages of direct measurement of the pure solvent HRS signal are straightforward and beneficial for more accurate determination of the hyperpolarizability of organic molecules of both basic and applied importance. Furthermore, this would make it possible to compare HRS data from different laboratories.

Acknowledgment. H.F.W. thanks Richard Bersohn for the discussion and suggestions on hyper-Rayleigh scattering in solution. H.F.W. also thanks the support from the Chinese Academy of Sciences (the Hundred Talent Project starting fund and CAS No. KJCXZ-Hz-05), the Natural Science Foundation of China (NSFC No. 29873059), and the Chinese Ministry of Science and Technology (MOST No. G1999075305).

References and Notes

- (1) Duxbury, D. F. *Chem. Rev.* **1993**, *93*, 381.
- (2) Cremers, D. A.; Windsor, M. W. *Chem. Phys. Lett.* **1980**, *71*, 27.
- (3) Sundstrom, V.; Gillbro, T.; Bergstrom, H. *Chem. Phys.* **1982**, *73*, 439.
- (4) Bhasikuttan, A. C.; Sapre, A. V.; Okada, T. *J. Phys. Chem. A* **2003**, *107*, 3030.
- (5) Zyss, J.; Ledoux, I. *Chem. Rev.* **1994**, *94*, 77.
- (6) Hendrickx, E.; Clays, K.; Persoons, A. *Acc. Chem. Res.* **1998**, *31*, 675.
- (7) Johnson, R. C.; Hupp, J. T. *The Spectrum* **2000**, *13*, 1.
- (8) Elsaesser, T.; Kaiser, W. *Annu. Rev. Phys. Chem.* **1991**, *42*, 83.
- (9) Yoshizawa, M.; Suzuki, K.; Kubo, A.; Saikan, S. *Chem. Phys. Lett.* **1998**, *290*, 43.
- (10) Green, F. J. *The Sigma-Aldrich Handbook of Stains, Dyes*; Aldrich Chemical Co.: Milwaukee, Wisconsin, 1990.
- (11) Beljonne, D.; Wenseleers, W.; Zojer, E.; Shuai, Z. G.; Vogel, H.; Pond, S. J. K.; Perry, J. W.; Marder, S. R.; Bredas, J. L. *Adv. Funct. Mater.* **2002**, *12*, 631.
- (12) Terhune, R. W.; Maker, P. D.; Savage, C. M. *Phys. Rev. Lett.* **1965**, *14*, 681.
- (13) Bersohn, R.; Pao, Y. H.; Frisch, H. L. *J. Chem. Phys.* **1966**, *45*, 3184.
- (14) Kielich, S. *J. Opt. Soc. Am. B* **1983**, *20*, 157.
- (15) Clays, K.; Persoons, A. *Phys. Rev. Lett.* **1991**, *66*, 2980.
- (16) Olbrechts, G.; Strobbe, R.; Clays, K.; Persoons, A. *Rev. Sci. Instrum.* **1998**, *69*, 2233.
- (17) Chui, T. W.; Wong, K. Y. *J. Chem. Phys.* **1998**, *109*, 1391.
- (18) Yaliraki, S. N.; Silbey, R. J. *J. Chem. Phys.* **1999**, *111*, 1561.
- (19) Lee, Y. K.; Jeon, S. J.; Cho, M. H. *J. Am. Chem. Soc.* **1998**, *120*, 10921.
- (20) Clays, K.; Persoons, A. *Rev. Sci. Instrum.* **1994**, *65*, 2190.
- (21) Wostyn, K.; Binnemans, K.; Clays, K.; Persoons, A. *Rev. Sci. Instrum.* **2001**, *72*, 3215.
- (22) Stadler, S.; Bourhill, G.; Brauchle, C. *J. Phys. Chem.* **1996**, *100*, 6927.
- (23) Noordman, O. F. J.; Vanhulst, N. F. *Chem. Phys. Lett.* **1996**, *253*, 145.
- (24) Lu, R.; Rao, Y.; Zhang, W. K.; Wang, H. F. *Proc. SPIE Nonlinear Spectroscopy* **2002**, *4812*, 115.
- (25) Rao, Y.; Tao, Y. S.; Wang, H. F. *J. Chem. Phys.* **2003**, *119*, 5226.
- (26) McClain, W. M.; Harris, R. A. Two-photon molecular spectroscopy in liquids and gases. In *Excited States*; Lim, E. C., Ed.; Academic Press: New York, 1977; Vol. 3.
- (27) Kaatz, P.; Shelton, D. P. *J. Chem. Phys.* **1996**, *105*, 3918.
- (28) Xu, C.; Webb, W. W. *J. Opt. Soc. Am. B* **1996**, *13*, 481.
- (29) Fischer, A.; Cremer, C. S. E. H. K. *Appl. Opt.* **1995**, *34*, 1989.
- (30) Long, D. A. *The Raman Effect*; John Wiley and Sons Inc.: West Sussex, England, 2002.
- (31) Morrison, I. D.; Denning, R. G.; Laidlaw, W. M.; Stammers, M. A. *Rev. Sci. Instrum.* **1996**, *67*, 1445.
- (32) Verbiest, T.; Kauranen, M.; Persoons, A.; Ikonen, M.; Kurkela, J.; Lemmetyinen, H. *J. Am. Chem. Soc.* **1994**, *116*, 9203.
- (33) Pauley, M. A.; Guan, H. W.; Wang, C. H.; Jen, A. K. Y. *J. Chem. Phys.* **1996**, *104*, 7821.
- (34) Kaatz, P.; Donley, E. A.; Shelton, D. P. *J. Chem. Phys.* **1998**, *108*, 849.
- (35) Maker, P. D. In *Physics of Quantum Electronics*; Kelly, P. L., Lax, B., Tannenwald, P. E., Eds.; McGraw-Hill: New York, 1966.